

BEAR CREEK TOWNSHIP BUILDING DEPARTMENT

373 N. DIVISION RD. PETOSKEY, MI 49770

Telephone 231-347-3204 Fax 231-347-0736

E-mail- building@bearcreektownship.com Website: bearcreektownship.com

Fireblocking Requirements

An often overlooked requirement of the building code, but typically discovered during a framing inspection, is the installation of code compliant fireblocking in wall, ceiling and floor framing. When a fire spreads, flames and harmful gasses spread through a building. If properly fireblocked, the movement of those flames and gasses is restricted, and the fire can not spread as easily through concealed passages that may be present in the framing of a building. In the 2015 Michigan Residential Code (MRC), section R302.11 contains the requirements for fireblocking of wall, floor and ceiling framing in wood-frame construction. Section R302.11 states:

"Fireblocking shall be provided to cut off all concealed draft openings, both vertical and horizontal, and to form an effective fire barrier between stories, and between a top story and the roof space."

Code compliant fireblocking is required in the following locations:

- In concealed spaces of stud walls and partitions, including furred spaces and parallel rows of studs or staggered studs, vertically at ceiling and floor levels, and horizontally at intervals not exceeding 10 feet.
- At all interconnections between concealed vertical and horizontal spaces such as soffits, drop ceilings, cove ceilings, etc.
- In the concealed spaces between stair stringers at the top and bottom of a stair run.
- At open spaces around chimneys and fireplaces, such as floor and ceiling penetrations.
- At tub/shower drain floor penetrations or in walls surrounding tub/shower units.

When installed properly, the fireblocking will aid in keeping, or at least slow a fire from spreading from one area to another. The materials that can be approved as fireblocking are listed in section R302.11.1. The list of approved materials includes:

- 2 inch thick nominal lumber.
- 2 thicknesses of 1 inch nominal lumber with staggered lap joints.
- 1 thickness of 23/32 inch wood structural panel with joints backed by 23/32 inch wood structural panel material.
- 3/4 inch particle board with joints backed up by 3/4 inch particle board.
- 1/2 inch gypsum board.
- 1/4 inch cement based millboard.
- Batt or blankets of mineral wool or glass fiber insulation installed so that the material is securely held in place. Glass fiber insulation, when used as fireblocking must be unfaced. Paper-facing is flammable, and would aid in the spread of fire. The insulation must fill the entire cross section of the wall cavity for a minimum height of 16 inches, measured vertically, below the ceiling or soffit drop. When the wall cavity contains obstructions such as pipes, wires, ducts, etc. the insulation must be tightly packed at the plate or blocking line, around the obstruction.

Blown in, or loose-fill insulation must be specifically approved for use as a fireblock. If the insulation is not approved for use as fireblocking, another approved method of fireblocking must be used when fireblocking is required in a wall cavity. At openings around vents, pipes, and ducts, at ceiling and floor levels, fireblocking is also required. Fireblocking in these areas must be of an approved material that will resist the passage of flame, gasses and smoke. Floor and ceiling penetrations of fireplaces and chimneys must be fireblocked with a non-combustible material, as per section 1001.12 of the 2015 MRC.

Top and bottom wall plate penetrations, such as pipes, wires and ducts, must be properly fireblocked (also known as firestopped) as well. The top and bottom wall plates act as fireblocking. When these wall plates are penetrated, the wall plate is no longer effective as a fireblock. Firestop caulk is an excellent method of firestopping of top and bottom wall plate penetrations. In some instances, the building code does allow for the use of fiberglass insulation, tightly packed around the penetrations. When using other materials that are not mentioned in the code approved methods, check with your local building code office to verify the material intended for use as an approved product.

The diagrams provided on the opposite side of this page are examples of where fireblocking is required, and how fireblocking can be achieved in those spaces.

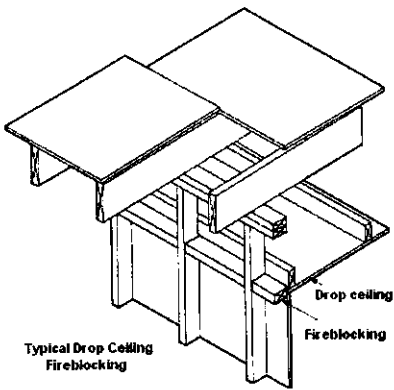

Typical Drop Ceiling Fireblocking

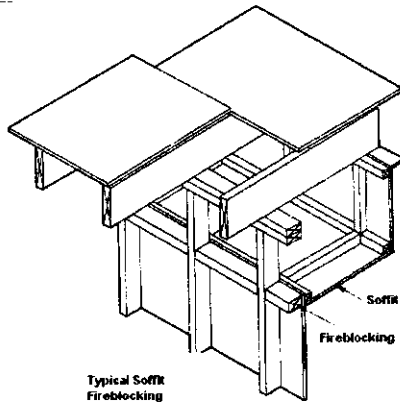

Typical Soffit Fireblocking

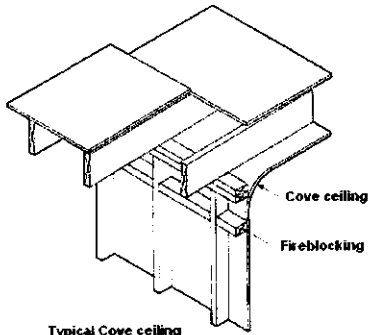

Typical Cove ceiling Fireblocking

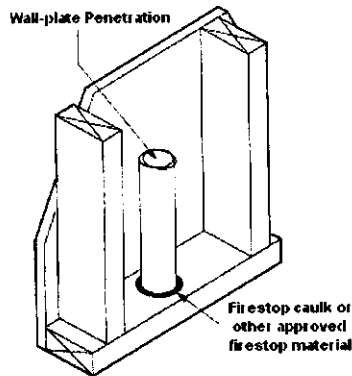

Typical Wall-plate Firestopping Detail

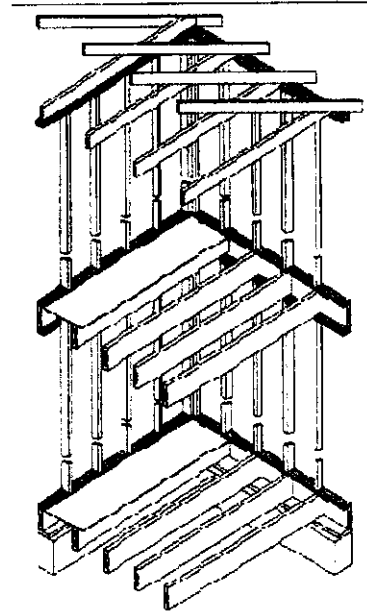

Typical Platform Framing
Fireblocking shown in grey

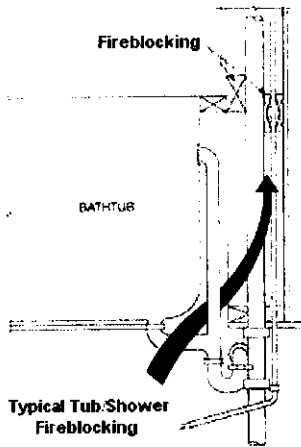

Typical Tub/Shower Fireblocking

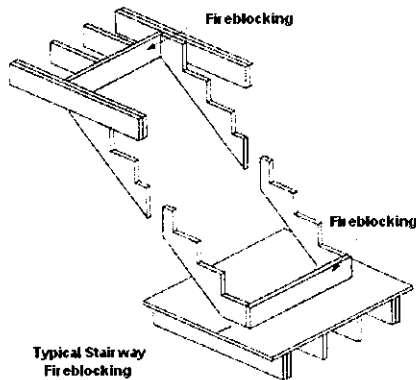

Typical Stairway Fireblocking

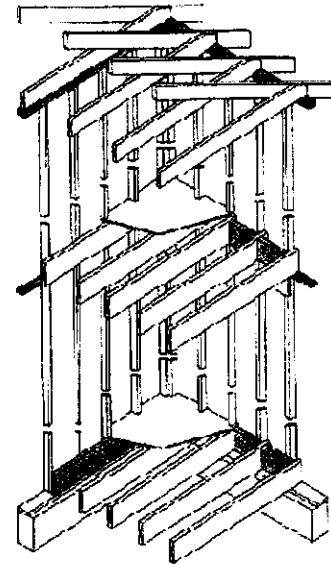

Typical Balloon Framing
Fireblocking shown in grey areas

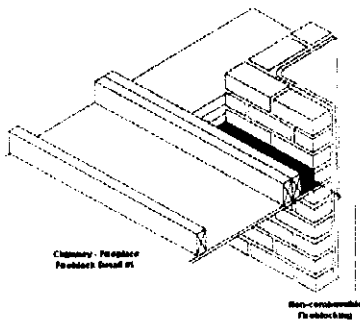

Chimney - Fireplace Fireblock Detail #1

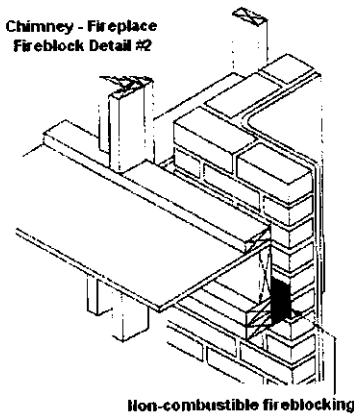

Chimney - Fireplace Fireblock Detail #2

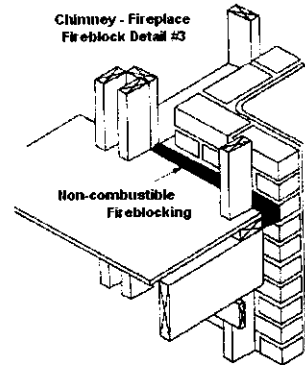

Chimney - Fireplace Fireblock Detail #3